

Introduction

The NetworkThermostat flush mount remote sensor is designed to work in conjunction with the NT-IDS remote sensor module or any other thermostat electronics using a 10K type III thermistor sensing mechanism. One (1) sensor can be connected each NT-IDS, replacing the internal sensor included in the NT-IDS electronics. The NT-FS is a 10K type III thermistor in a special enclosure for mounting in sheetrock on in wood, giving a nearly invisible method of sensing temperature.

Drywall (Sheetrock) Installation

1. Pre-Wire For NT-FS Sensor:

- a. Select a location on an INTERNAL wall within the space where the temperature is to be measured. Placement close to a return air duct at approximately 4' to 6' above the finished floor is typically ideal.

DO NOT install on an external wall.

DO NOT install where direct sunlight will shine on the sensor any time of year.

DO NOT install above or around sources of heat/cold such as in-wall water pipes, above electrical dimmers.

- b. Pull a CAT5 cable from the remote sensor electronics (such as the NT-IDS) location to the desired sensor location.
- c. Anchor the CAT5 cable to a stud about 12" to 18" above the mounting location to ensure the cable doesn't get lost in the wall or dropped to the floor behind the sheetrock.
- d. Leave about 24" of cable behind the wall for pull through.
- e. Place a small hole in the sheetrock at the mounting location and pull CAT5 cable through the hole in the sheetrock for future termination
- f. Place a 24" x 24" piece of insulation inside the wall, around the location where the sensor is to be located. This will assist with insulating the in-wall for future termination.
- g. Mount the sheetrock to the wall.

2. Connect the NT-FS Sensor and Mount the Anchor:

- a. Push the CAT5 cable back into the wall. The cable will be held up by the anchor and the insulation.
- b. Using a paddle bit, countersink a 3/4" hole in the sheetrock, making the hole depth 1/16" deep, being careful not to wallow out the hole.
DO NOT make this hole deeper than 1/16".
- c. Then, using another paddle bit, drill a concentric 7/16" hole completely through the sheetrock, being careful not to wallow out the hole.
- d. Using thin needle-nosed pliers or paperclip, grab the CAT5 cable and pull it back through the wall.
- e. Strip back about 12" of the CAT5 jacket and select a single pair of the cable. Untwist about 6" of the cable and strip about 1/2" of insulation off of each conductor on the selected pair. Cut the remaining pairs off at the edge of the stripped jacket.
- f. Feed the cable through the small end of the anchor and pull all excess cable through the anchor.
- g. Slide the NT-FS sensor through the NT-FS anchor and connect the sensor wires to the CAT5 wire pair using two small wire nuts for butt-end connectors. Feed the excess cabling back into the wall.
- h. Carefully move the cable to one side of the inner wall of the anchor, and then use a wide flat blade screwdriver (or a dime) to install the anchor into the 7/16" opening and tighten until the anchor is recessed about 1/16" below the face of the sheetrock.
DO NOT OVERTIGHTEN. OVERTIGHTENING WILL CAUSE THE SHEETROCK TO CRUMBLE AND MAKE THE INSTALLATION FAIL.

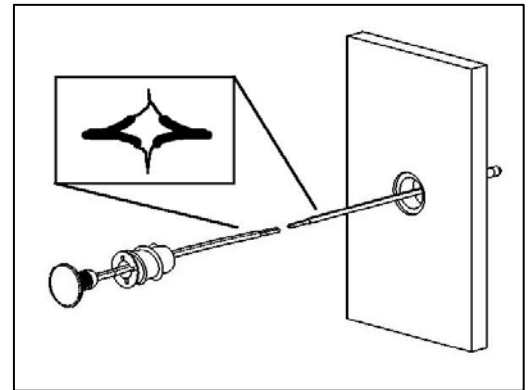

3. Mounting the NT-FS Sensor:

- a. Carefully feed the remaining cable back into the wall, through the anchor.
- b. Push the sensor head into the anchor, stopping when the top of the sensor is flush with the sheetrock.

4. Finishing/Covering the NT-FS Sensor:

- a. PAINTING:
 1. Very lightly mud around the sensor head and sand to a smooth finish, keeping the amount of mud as thin as possible on the top of the sensor.
 2. Paint the surface, again keeping the amount of paint as thin as possible.

NOTE: THE THICKER THE MUD & PAINT, THE LESS RESPONSIVE THE SENSOR WILL BE. BE CAREFUL NOT TO RENDER THE SENSOR INOPERABLE BY USING THICK PLASTER OR OTHER HEAVILY TEXTURED COVERING.

- b. WALLPAPER:

1. Very lightly mud around the sensor head and sand to a smooth finish, keeping the amount of mud as thin as possible on the top of the sensor.
2. Apply the wallpaper, keeping the amount of glue as thin as possible.

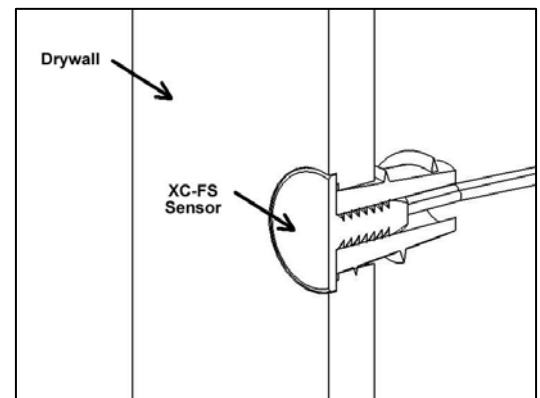

Wood Installation

1. Pre-Wire For NT-FS Sensor:

- Select a location on an INTERNAL wall within the space where the temperature is to be measured. Placement close to a return air duct at approximately 4' to 6' above the finished floor is typically ideal.

DO NOT install on an external wall.

DO NOT install where direct sunlight will shine on the sensor any time of year.

DO NOT install above or around sources of heat/cold such as in-wall water pipes, above electrical dimmers.

- Pull a CAT5 cable from the remote sensor electronics (such as the NT-IDS) location to the desired sensor location.
- Anchor the CAT5 cable to a stud about 12" to 18" above the mounting location to ensure the cable doesn't get lost in the wall or dropped to the floor behind the wall.
- Leave about 24" of cable behind the wall for pull through.
- Using a paddle bit, countersink a 3/4" hole in the wood, making the hole depth 1/16" deep, being careful not to wallow out the hole.
DO NOT make this hole deeper than 1/16".
- Then, using another paddle bit, drill a concentric 9/32" hole completely through the sheetrock, being careful not to wallow out the hole.
- Place a 24" x 24" piece of insulation inside the wall, around the location where the sensor is to be located. This will assist with insulating the in-wall for future termination.
- Using thin needle-nosed pliers or paperclip, grab the CAT5 cable and pull it through the opening.
- Mount paneling or other rigid wall material.

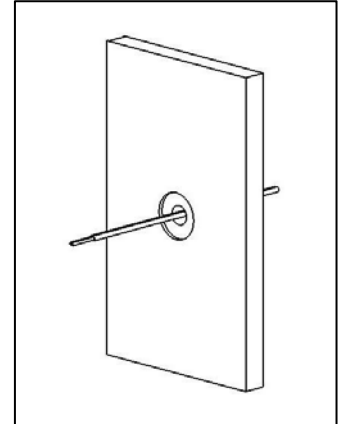

2. Connecting the NT-FS Sensor:

- Strip back about 12" of the CAT5 jacket and select a single pair of the cable. Untwist about 6" of the cable and strip about 1" of insulation off of each conductor on the selected pair. Cut the remaining pairs off at the edge of the stripped jacket.
- Slide a 2" piece of small heat shrink over the end of each of the conductor and slide back as far as possible.
- Using a soldering iron (the battery-powered, instant on/off versions work great), twist together and solder one conductor to one lead of the sensor, and the other conductor to the other lead.
- Slide the heat shrink tubing over each conductor, and using a match or a hot hairdryer, heat the tubing and secure around the soldered wires.

3. Mounting the NT-FS Sensor:

- Carefully feed the cable back into the wall, through the anchor.
- Push the sensor head into the wall, stopping when the top of the sensor is flush with the finished wall.

4. Finishing/Covering the NT-FS Sensor:

- PAINTING:**
 - Very lightly mud around the sensor head and sand to a smooth finish, keeping the amount of mud as thin as possible on the top of the sensor.
 - Paint the surface, again keeping the amount of paint as thin as possible.

NOTE: THE THICKER THE PAINT OR STAIN, THE LESS RESPONSIVE THE SENSOR WILL BE. BE CAREFUL NOT TO RENDER THE SENSOR INOPERABLE BY USING THICK PAINT OR STAIN.

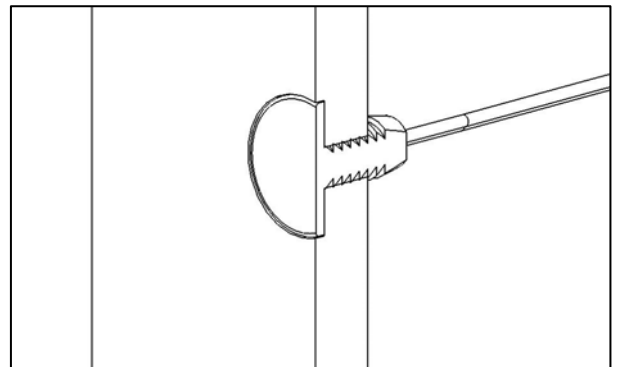

Connection to NT-IDS

- Mount the NT-IDS in a location that is accessible for future maintenance.
- Clip the internal thermistor on the NT-IDS, as shown.
- Connect the two-wire cable from the NT-FS sensor to terminals 1 and 2 of the NT-IDS electronics.

